

HEXATECH	Electrical Method Statement for transformer installation	Issue No: 1	Effective Date: 01/03/17
		Rev No: 0	Document Ref: MS-E011

1.0 OBJECTIVE OF PROCEDURE

This procedure provides unloading and installation for a transformer at Project site with quality control and Safety Plan pertaining to this project.

2.0 SCOPE OF WORKS

Method of installation is accordance to latest electrical standard practice and local authority standards. The scope is to install a cast resin transformer at the substation.

3.0 TOOLS AND EQUIPMENTS

ITEM	DESCRIPTION
1	Crane, Hoist , Lifting Belt, Pipe Roller, Palette truck, & forklift

4.0 SAFETY & ENVIRONMENTAL PROGRAMME

- 4.1 All installation works will be carried-out in accordance with Project Safety Plan, Owner Safety Procedures and statutory regulations.
- 4.2 All necessary personal protective equipment will be provided and worn.
- 4.3 All the tools and equipment used at site must be compliance to safety requirement.
- 4.4 The site of all work activities will be kept in clean and tidy manner.

5.0 WORK METHOD STATEMENT

Prior to delivery of transformer (FAT) factory acceptance test must be conducted and site is should be ready to accept the equipment, the following site observation and plan must be done;

- 5.1 Transportation routing, unloading area, access & storage must be studied.
- 5.2 Visual inspection of switch room to ensure no opening/services which lead to water trap is within the room especially the ceiling level.
- 5.3 Ensure wall/door opening is big enough for the access of the transformer into the room.
- 5.4 To visual inspect floor base mounting dimension onto the floor. Transformer positioning must accessible from front and back for future upgrading/maintenance.
- 5.5 Installation method shall as per manufacturer recommendation procedure

HEXATECH	Electrical Method Statement for transformer installation	Issue No: 1	Effective Date: 01/03/17
		Rev No: 0	Document Ref: MS-E011

Handling

The transformer may only be unloaded and transported by means of the lifting lug provided on the upper constructional cross beam as shown in fig. 1. Four cords have to be used. The information about pulling at the angle provided on the labels on the lifting lugs must be observed as fig. 2

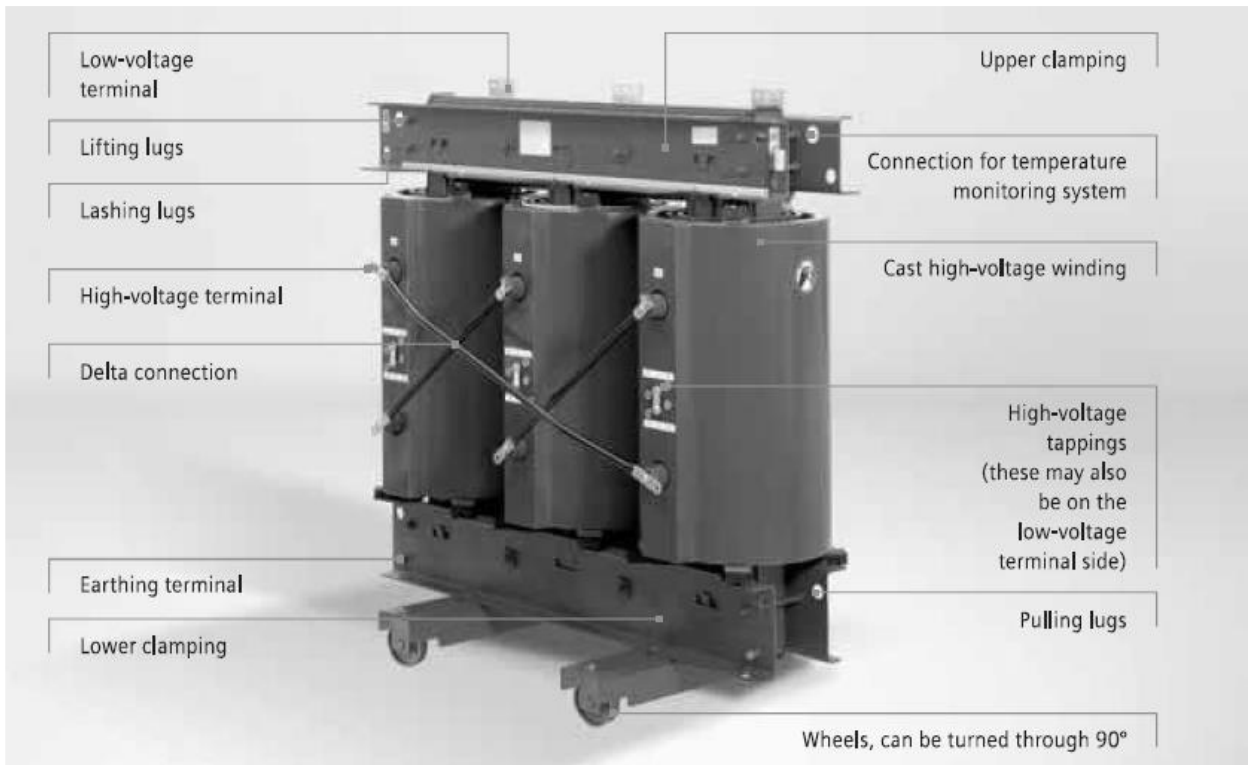

Fig. 1 Cast Resin Transformer

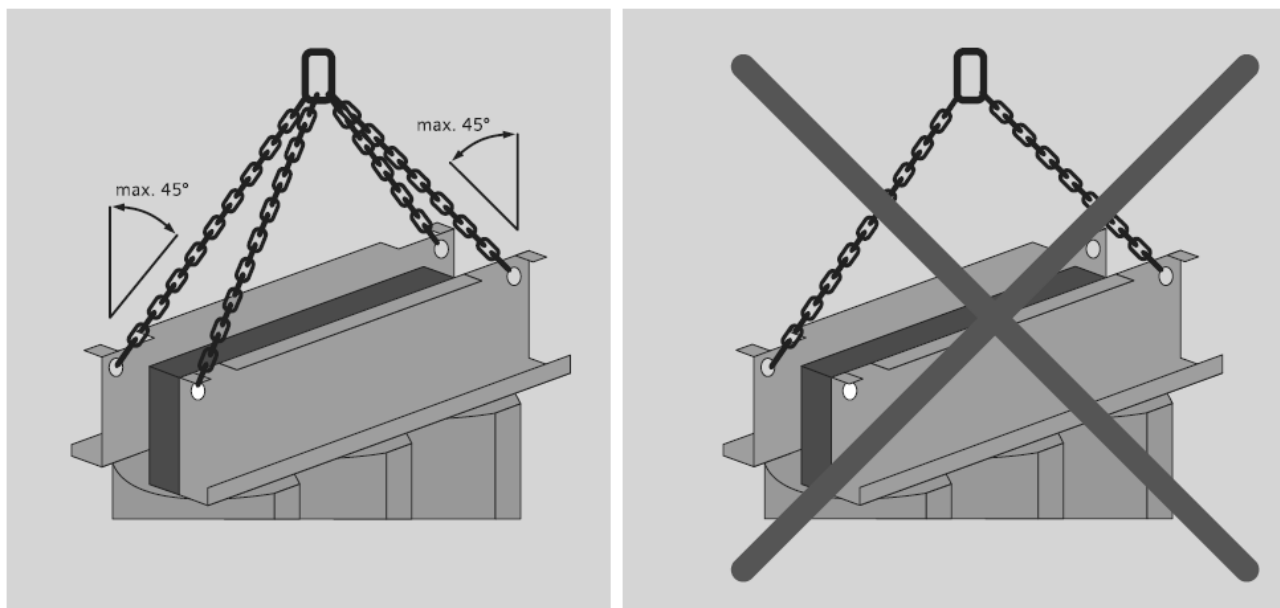

Fig. 2 Lifting lugs

HEXATECH	Electrical Method Statement for transformer installation	Issue No: 1	Effective Date: 01/03/17
		Rev No: 0	Document Ref: MS-E011

Unloading

The equipment is lifted up using a crane and will be unloaded to the platform with steel plate below the transformer.

Transformer will be unloaded as close as possible to the front of the substation room floor.

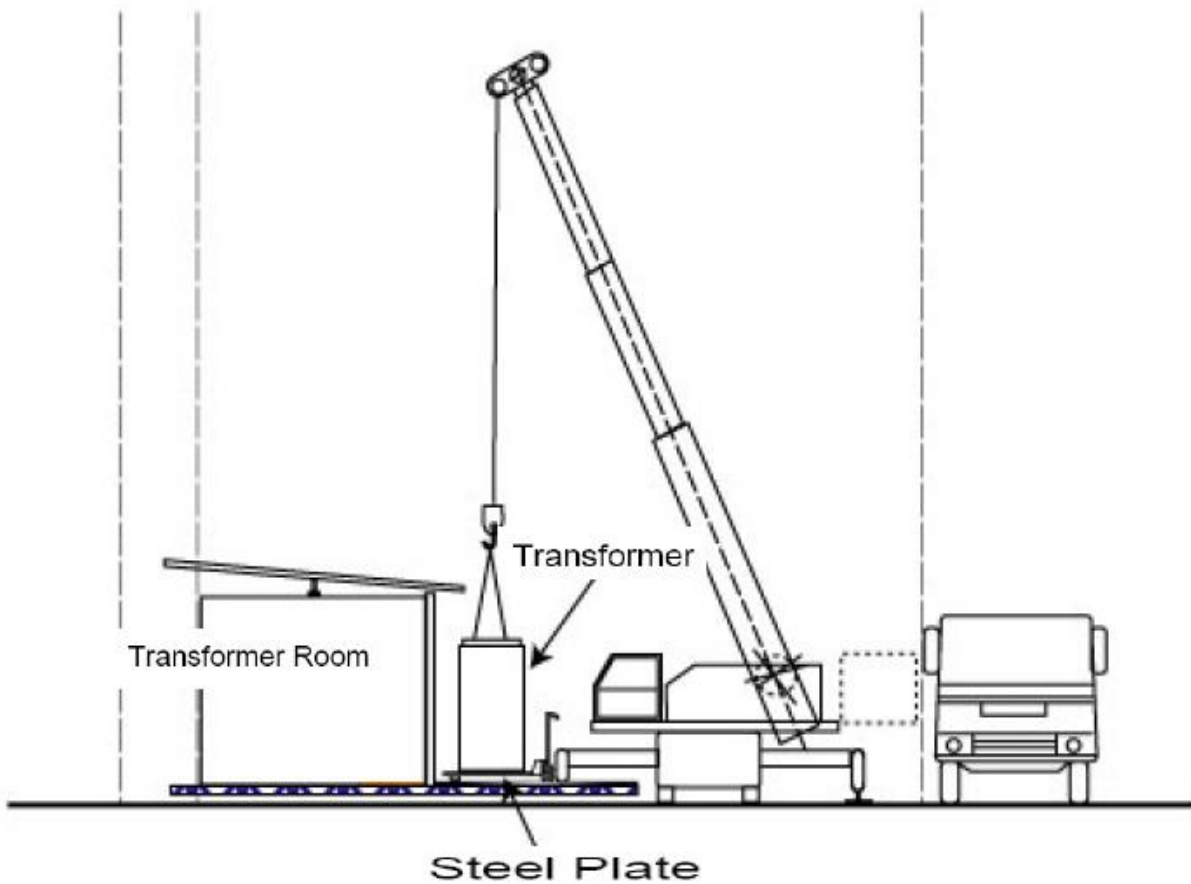

Fig. 3 Side view of Crane and Trailer

HEXATECH	Electrical Method Statement for transformer installation	Issue No: 1	Effective Date: 01/03/17
		Rev No: 0	Document Ref: MS-E011

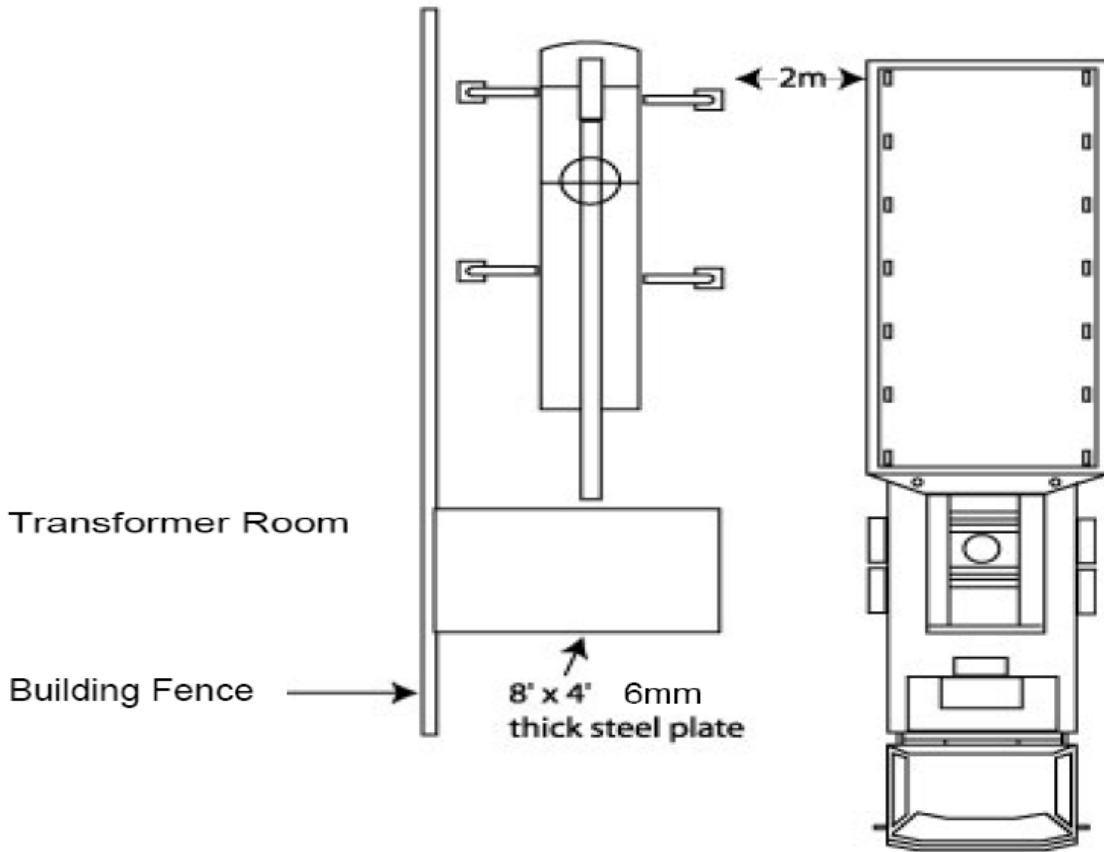

Fig. 4 Plan view of Crane and Trailer

Once the transformer with roller wheel below is unloaded on the steel plate; the transformer is pushed by manpower to various position as indicated in fig. 5.

The transformer will then be positioned at the desired location and the roller wheel will be fixed using angle iron until final position.

HEXATECH	Electrical Method Statement for transformer installation	Issue No: 1	Effective Date: 01/03/17
		Rev No: 0	Document Ref: MS-E011

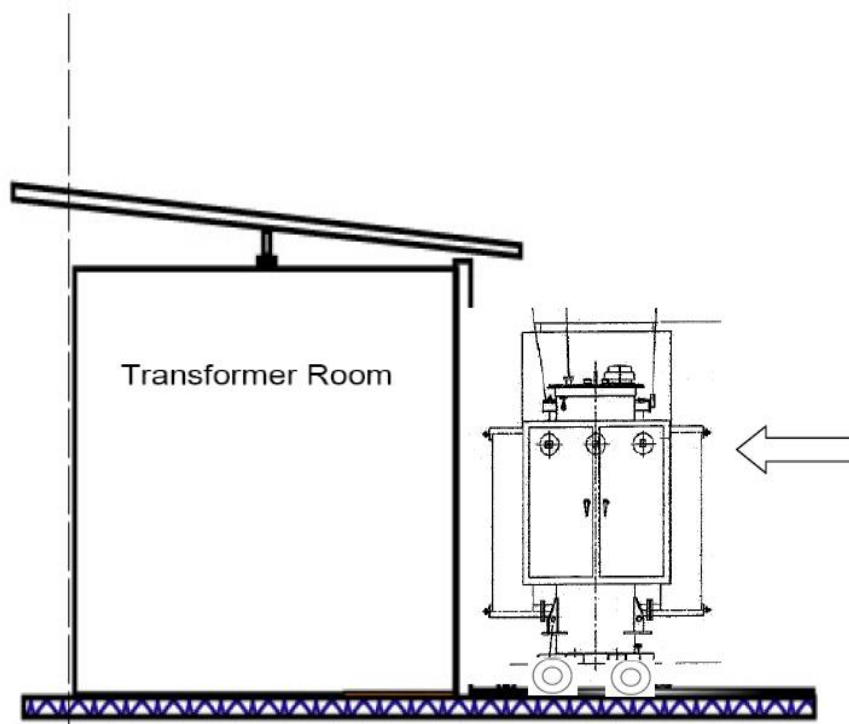

Fig. 5 Side view pushing Transformer into Substation

Transformer housing installation

Upon transformer unloading at the desired position transformer enclosure to be assembled at site.

Sheet metal plate will be delivered loose to site. Assembly of enclosure will be started from bottom to top portion. Adequate space must always refer to minimum clearance for transformer to prevent any flashover. The standard is shown table 1 and fig. 6.

Maximum voltage for equipment $U_m^{(1)}$ (rms value)	Rated lightning impulse withstand voltage $U_{LI}^{(1)}$		Minimum clearances			
	List 1	List 2	a	b	c	d
kV	kV	kV	mm	mm	mm	mm
12	–	75	120	*	50	40
24	95	–	160	*	80	50
24	–	125	220	*	100	70
36	145	–	270	*	120	90
36	–	170	320	*	160	110

Table 1

HEXATECH	Electrical Method Statement for transformer installation	Issue No: 1	Effective Date: 01/03/17
		Rev No: 0	Document Ref: MS-E011

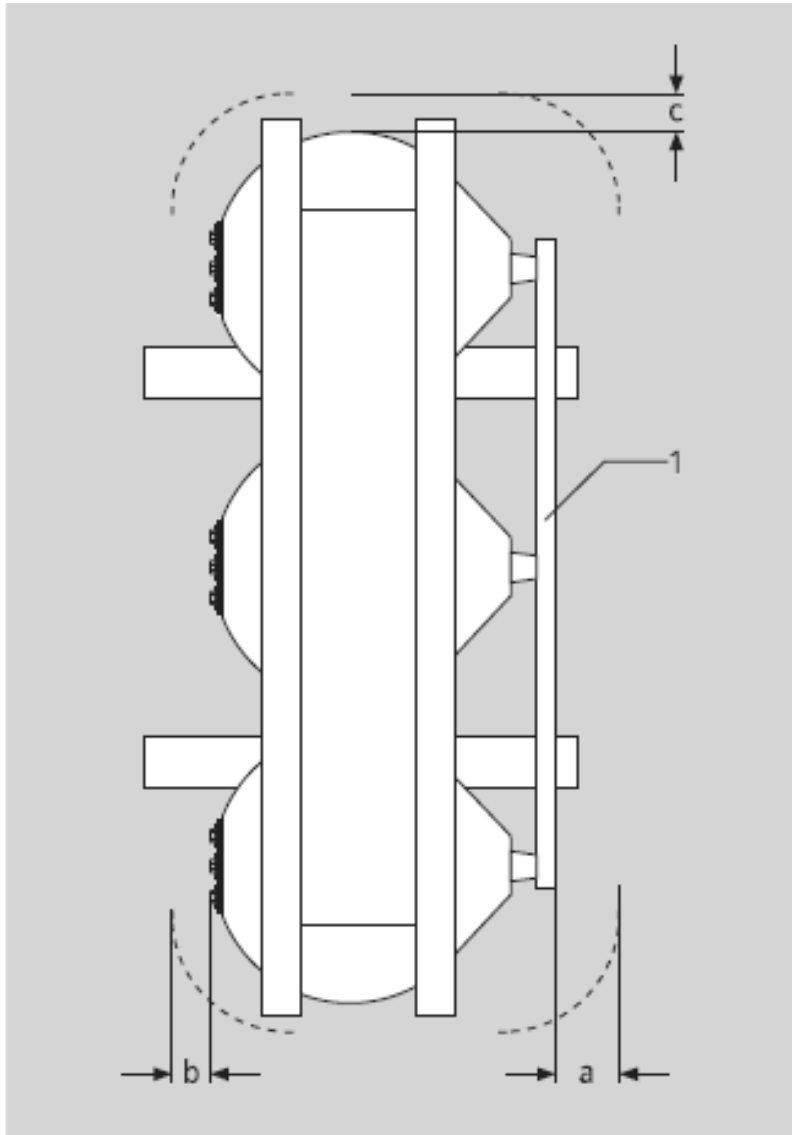

Fig. 6 Minimum clearance for transformer