

HEXATECH	Electrical Method Statement for Busway Installation	Issue No: 1	Effective Date: 01/03/17
		Rev No: 0	Document Ref: MS-E013

1.0 OBEJECTIVE

This procedure provides detail for the installation of electrical busway.

2.0 SCOPE OF WORKS

Method of installation is in accordance to the latest IEC, IEE, MS and local authority standards.

3.0 TOOLS AND EQUIPMENTS

Scissor Lift, Scaffold, Rotation Meter, Clamp Meter, Insulation Tester, Torque Wrench, Spanners, Screw driver

4.0 RECEIVING, HANDLING AND STORAGE

4.1 Receiving

Upon reception, check the information on the shipping note corresponds to the equipment received to ensure all of the order has been received and shipped. Complaints concerning missing components or other errors must be sent in writing to the manufacturer within 30 days from the date the shipping item was received.

Upon reception, check the various units of the busway system immediately to identify any damage that has occurred during transport. If there is observed or suspected damage, file a claim immediately with the carrier and inform the nearest manufacturer office. Condition of unloaded material will be verified by client/PMC via Notification of Inspection & Receiving Material Inspection Report.

4.2 Handling

Handle the products with the greatest of care to avoid damaging the internal components of the system and to avoid changing the external appearance of the various parts, as well as the bar ends (connection terminals).

The busway must be constantly supported by independent means, in such a way its weight is not resting on the top of the transformers or Main Switch Boards. The distance between these support means must not exceed 1.5 meters

Avoid exposing the busway to twisting, embossing or impacts, and all other actions likely to causing damage.

HEXATECH	Electrical Method Statement for Busway Installation	Issue No: 1	Effective Date: 01/03/17
		Rev No: 0	Document Ref: MS-E013

Ensure the handling equipment available at the site of installation is suitable for handling busway. In particular, check the lifting capacity of the crane or the other lifting equipment to be used.

Take great care when unpacking the equipment:

- use a nail-head puller when unpacking wooden crates,
- if hauling the busway with a crane, use Nylon slings to spread the weight of the unit being lifted,
- if using cables, insert a spacing means to avoid damaging the busway,
- if using a forklift truck, position the busway on the forks in such a way the weight is evenly distributed.

1 - Cut the strapping holding the packaging case using suitable cutting tools.

2 -Use suitable tools to remove the strengthened steel packaging at each end of the busway. Take care not to damage the steel box so as not to damage the busway. Avoid the use of objects with sharp edges when lifting the busway.

3 - Dispose of all used packaging in an appropriate way.

Never drag the busway along the floor. Do not use the end bars to lift sections of the busway.

4.3 Storage

If the busway is not installed and commissioned immediately, leave it in the original packaging and store it in a clean and dry place at a uniform temperature.

The busway must not be stored outside. However, if outside storage is necessary, cover the busway in such a way as to protect it from bad weather and to avoid contact with the elements.

Temporary electrical heating must be provided for underneath the covering means to prevent condensation. The supplied heat must be of suitable temperature and uniformly distributed underneath the covering means.

During installation, take particular care to protect rising mains from humidity arising from unfinished roofs, walls and other similar elements.

HEXATECH	Electrical Method Statement for Busway Installation	Issue No: 1	Effective Date: 01/03/17
		Rev No: 0	Document Ref: MS-E013

5.0 WORK ACTIVITY METHODOLOGY / ARRANGEMENTS

5.1 Planning Stage

- Busway brand, spec and sizes used will be as per approved catalogue, data sheets and detailed manufacturer drawings. The routing will be as per approved shop drawing.
- The Busway shall not run close to, or traverse any pipe work.
- Adequate clearance shall be provided for future maintenance and repair.

5.2 Installation

General

- It is highly recommended that busway erection shall commence when the builder's work for the area/room/duct has been completed.
- The area/room/duct shall be in a dry and clean condition with lockable door.

Busway Support

- Follow manufacture's recommendations to use support to secure the installation.
- For this project a common support will be provided by the client
- Align vertically and horizontally before the final tightening of all joint bolts

Joint Assembly

- Must clean the contact surface so that it is free from contaminants before jointing
- If joint or joint assemblies are exposed to moisture, plaster, or any other type of contaminant, they shall be properly covered during installation.
- Standard method of joint assembly is shown in fig. 1 & 2

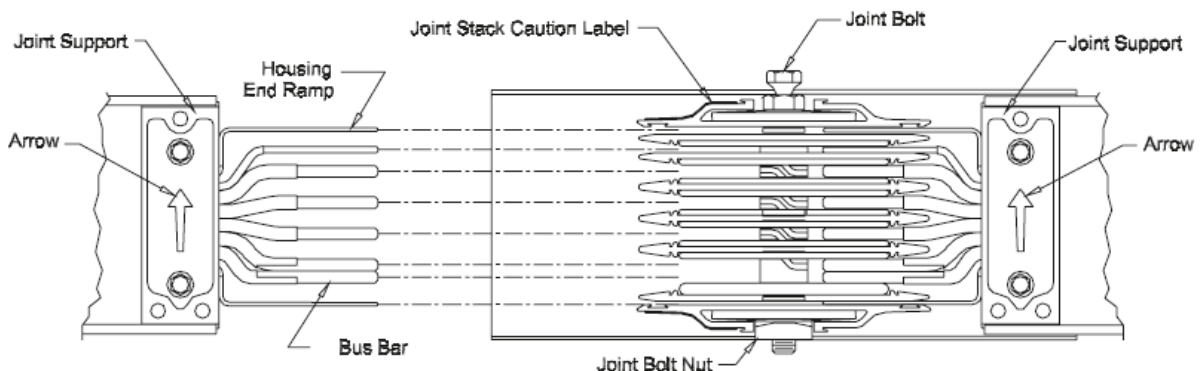

HEXATECH	Electrical Method Statement for Busway Installation	Issue No: 1	Effective Date: 01/03/17
		Rev No: 0	Document Ref: MS-E013

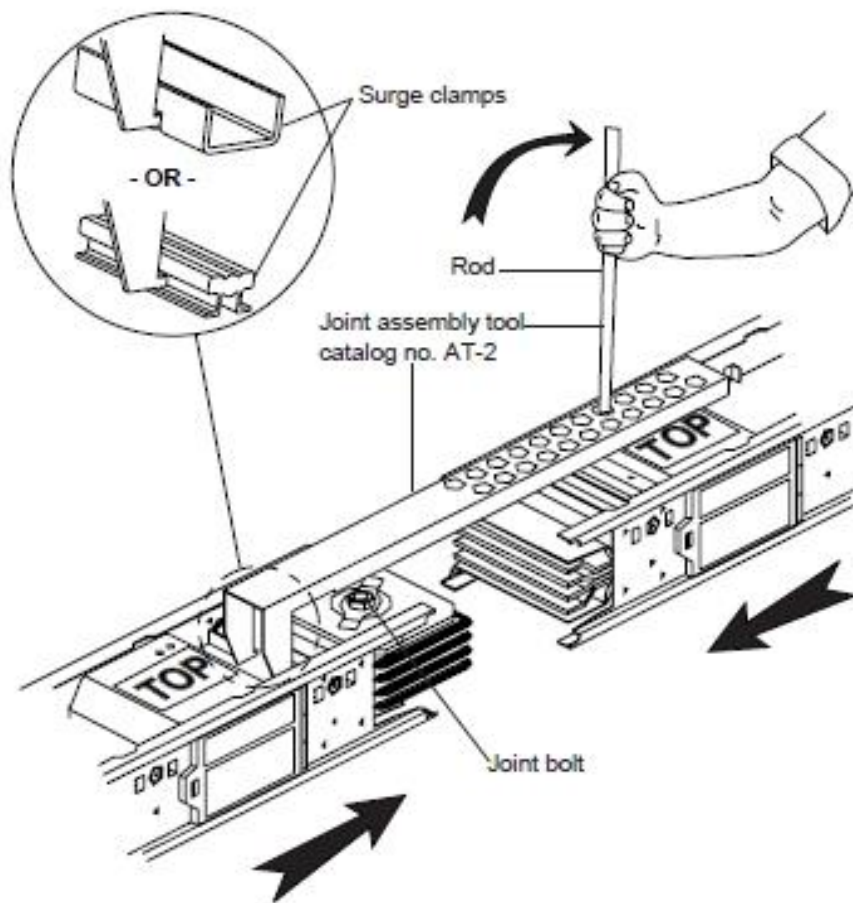
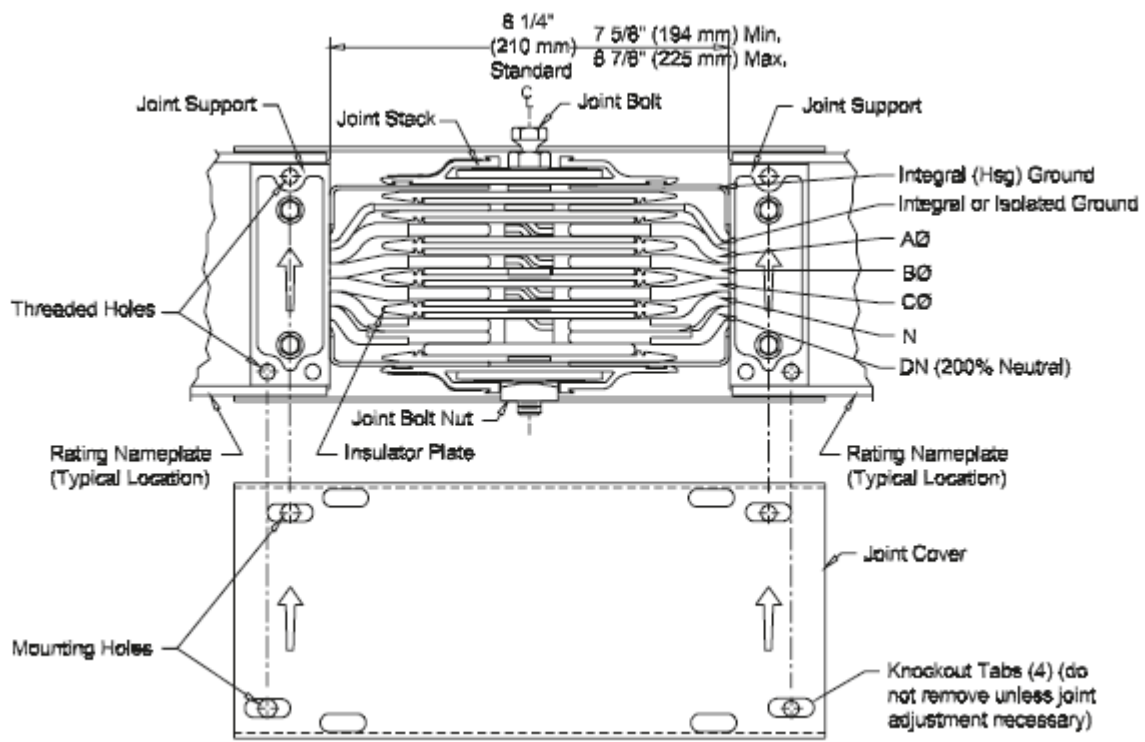

Installation Detail 1: Joint Assembly

HEXATECH	Electrical Method Statement for Busway Installation	Issue No: 1	Effective Date: 01/03/17
		Rev No: 0	Document Ref: MS-E013

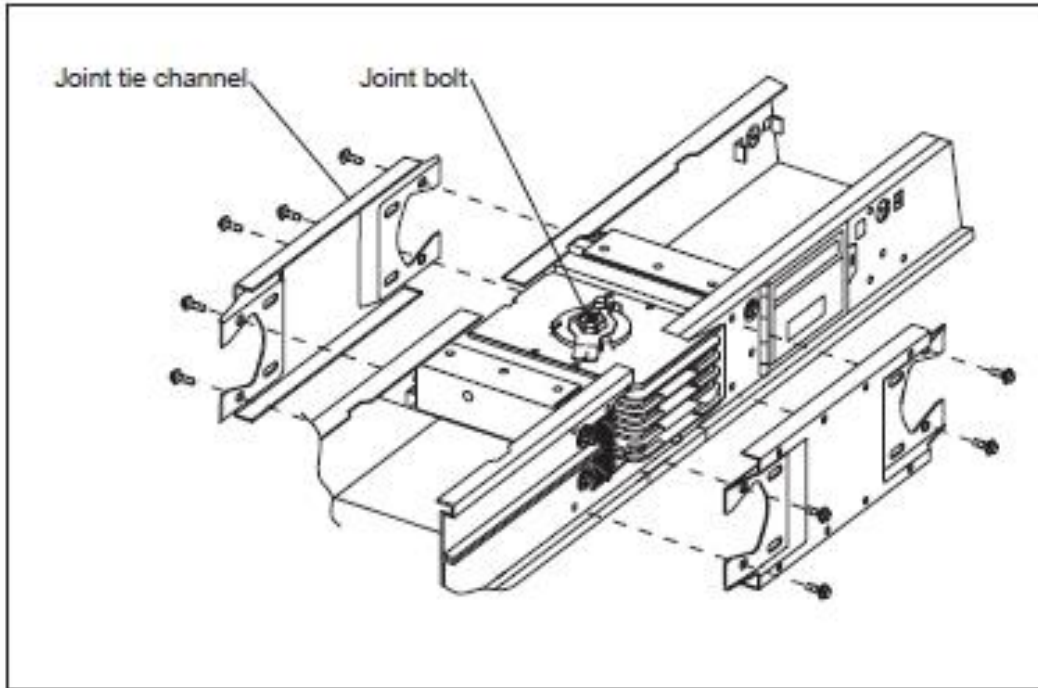

Installation Detail. 2: Installing joint tie channels

Flange End

- a. Flange end are used for the termination at the transformer and MSB.
- b. 4000A flexible coupling bars are used to connect the busbar flange with the MSB cooper bar.
- c. Fig. 3 show the connection between flange end & the flexible coupling

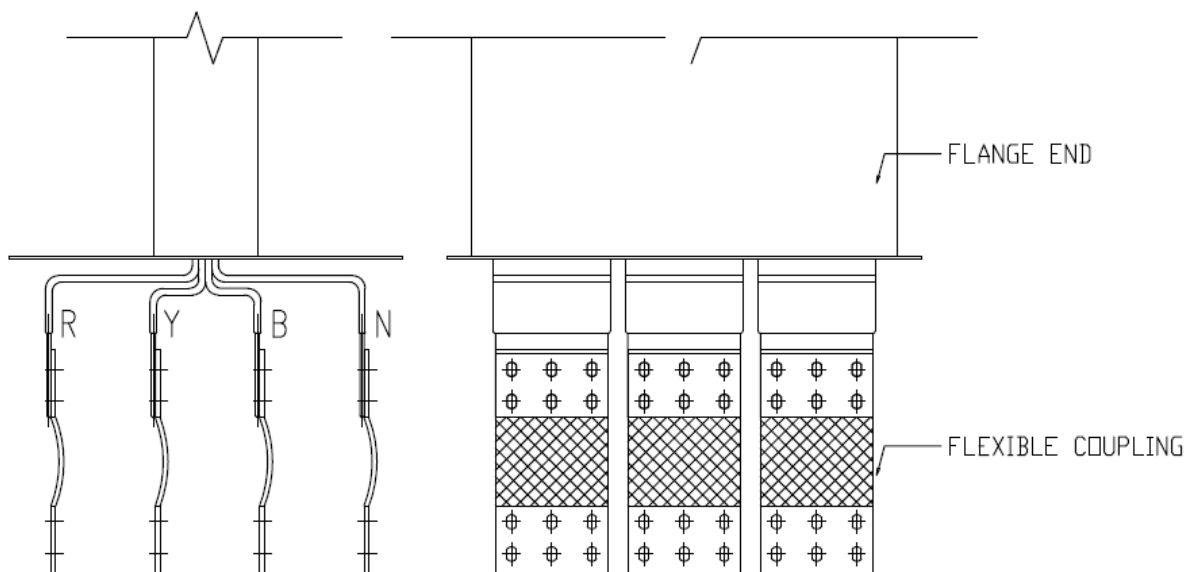

Installation Detail 3: Flange end & flexible coupling

HEXATECH	Electrical Method Statement for Busway Installation	Issue No: 1	Effective Date: 01/03/17
		Rev No: 0	Document Ref: MS-E013

6.0 Inspection, Testing and Commissioning

Inspection and Test Plans (ITP) shall include inspection at the following stage.

- a) Receiving of materials inspection
- b) In-process inspection during installation (Megger & IR Test)
- c) All testing and inspections will be documented with request for inspection form, attached progress pictures and test reports.

7.0 HEALTH, SAFETY, SECURITY AND ENVIRONMENT

- All installation works will be carried-out in accordance with Project Safety & Environmental Plan, Safety Procedures and statutory regulations.
- All necessary personal protective equipment will be provided and worn.
- All the tools and equipments used at site must be compliance to safety requirement.
- The site of all work activities will be kept in clean and tidy manner.
- Safety personnel will closely supervise and check the safety of the construction area. Safety measure will be intensified when the risks are higher during period of work.

8.0 List of References

- 8.1 Manufacturers Busway Installation Guide
- 8.2 General instruction for Handling, Installation, Operation, and Maintenance for Busway (NEMA STANDARDS PUBLICATIONS BU 1.1-2000)
- 8.3 Contract Specifications

9.0 LIST OF ATTACHMENTS

Attachment	Description	Remarks
1	Busway Installation Flowchart	

HEXATECH	Electrical Method Statement for Busway Installation	Issue No: 1	Effective Date: 01/03/17
		Rev No: 0	Document Ref: MS-E013

Busway Installation Flowchart

